

The venetian blind used in the ScreenLine® SL24P system is manufactured in accordance with high technical specifications and production standards. The venetian blind operation is achieved using a rotational magnetic transmission through the 'special' corner key, thereby guaranteeing the unit's hermetic seal. The tilting operation is achieved using a flexible wire drive via a rotational button on the window frame. The bottom rail of the blind is located on pins attached to the lateral side-guide that allow the blind to rotate through 180°.

Technical features

Magnet composition

The casing is in Nylon 66 reinforced with glass-fibre. The gears and transmission components are made from carbon steel, and conventional bearings are used for the drive shafts. The worm gear is in brass.

The magnets are manufactured from sintered neodymium, iron boron and have the following characteristics:

Produced Energy	Bh-max-Mg.Oe	33-35
Residual Induction	Br-Gauss	11.000 / 12.000
Coercive Force	He-Oestered	10.000
Max. Working temp.	°C	120
Curie Temperature	°C	310
Reversible Temperature Factor	°C	-0.12%

Head-rail Profile

Extruded aluminium A6063S-T5 alloy.

Dimensions: 24 mm width, 30 mm height + 6 mm external pelmet.

Anodised or powder coated to colour co-ordinate with the slats (RAL colour available on request).

Slats

Aluminium Aa6011-t8 alloy.

Dimensions: 16 mm width, 0.2 mm thick.

High resistance polyester paint: available in 13 colours.

The slats have a special Clarion® treatment to eliminate possible paint emissions by U-V or Solar radiation i.e. non-fogging.

Bottom rail Profile

Extruded aluminium A6063S-T5 alloy.

Dimension: 14 mm width, 11 mm height - comprising two interlocking profiles.

Anodised or powder coated to colour co-ordinate the slats (RAL colour available on request).

Ladder Tape

Thermo-fixed 100% polyester with 12 mm step.

Great dimensional stability with excellent U-V and Solar resistance.

Colour co-ordinated with slats.

Cord

Thermo-fixed 100% polyester with excellent dimensional stability.

1 mm dia. Colour – white.

Spacer

Extruded aluminium, electro-welded.

Dimension: 24 mm x 8 mm with corresponding corner keys.

Standard Knob

Black coated brass with mechanical stop to eliminate possible slat damage.

Flexible cable

Steel cable 3,2 mm diameter – anti-twist.

Protective sheath self-lubricating for longer life.

Size Parameters

Height	100~3.000 mm
Width	190~2.500 mm
Max. Area	see tables

SL24P Comprehensive drawing with component codes

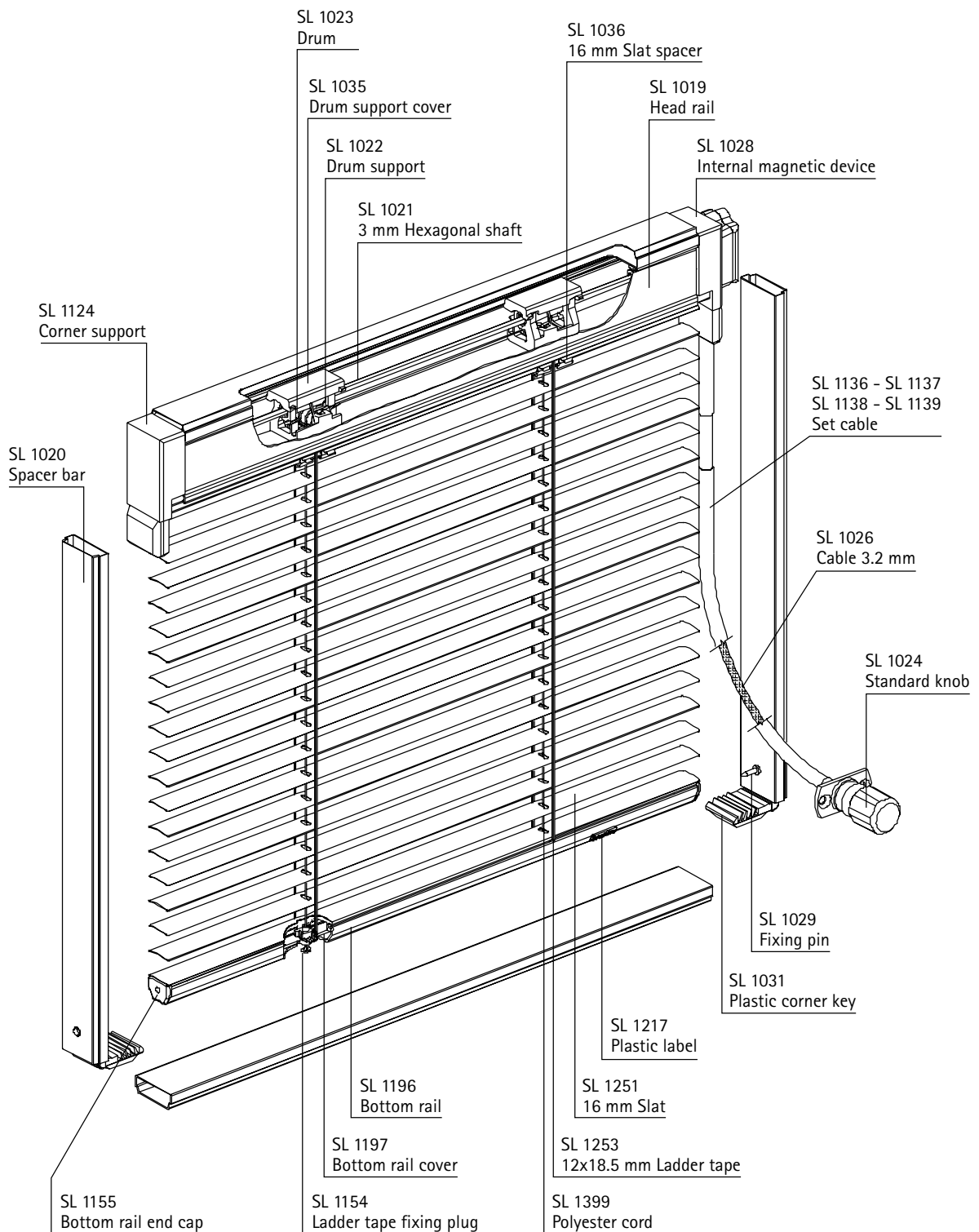

Double-glazed unit SL24P

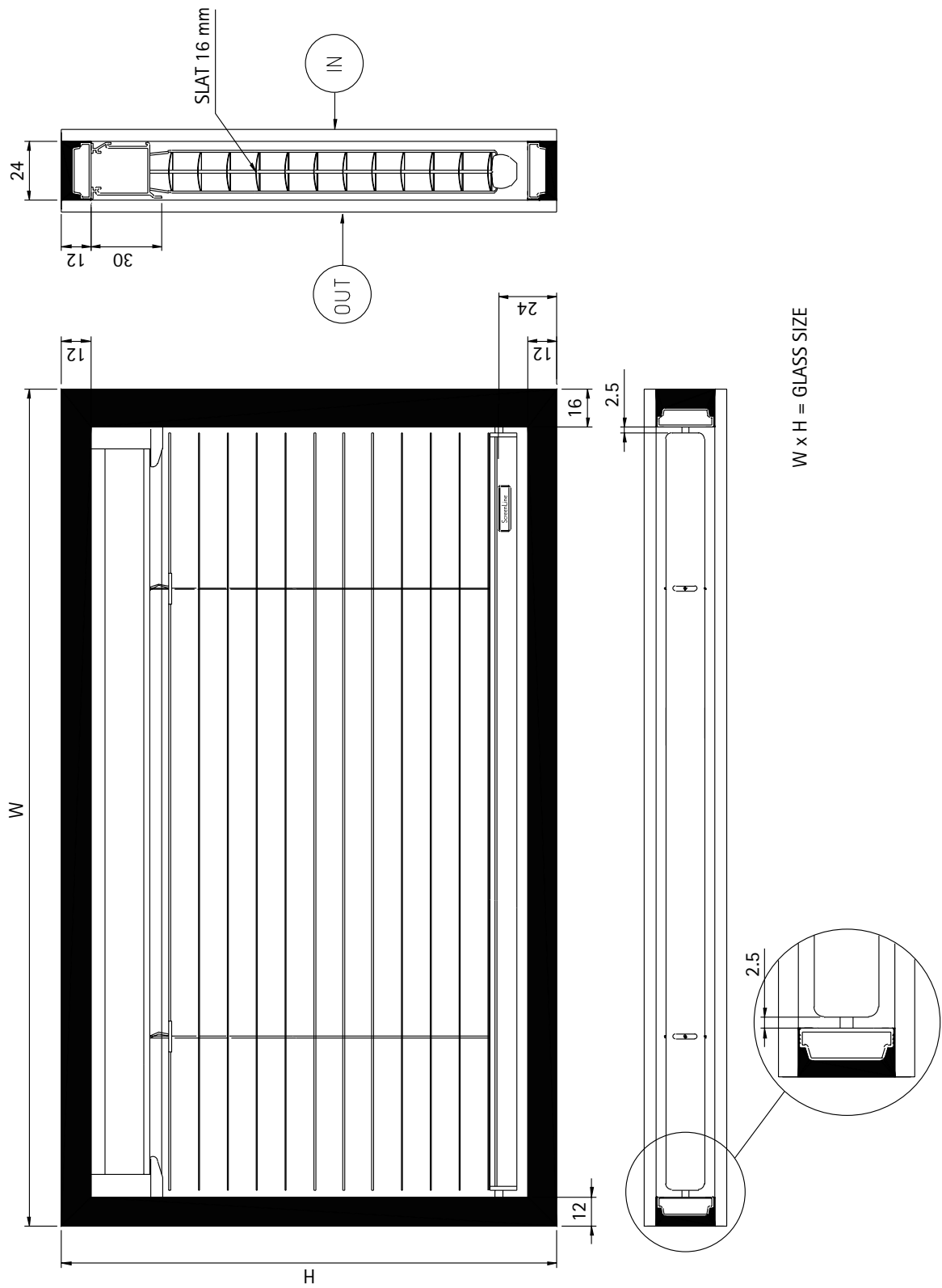

SL24P Double-glazed unit with standard knob

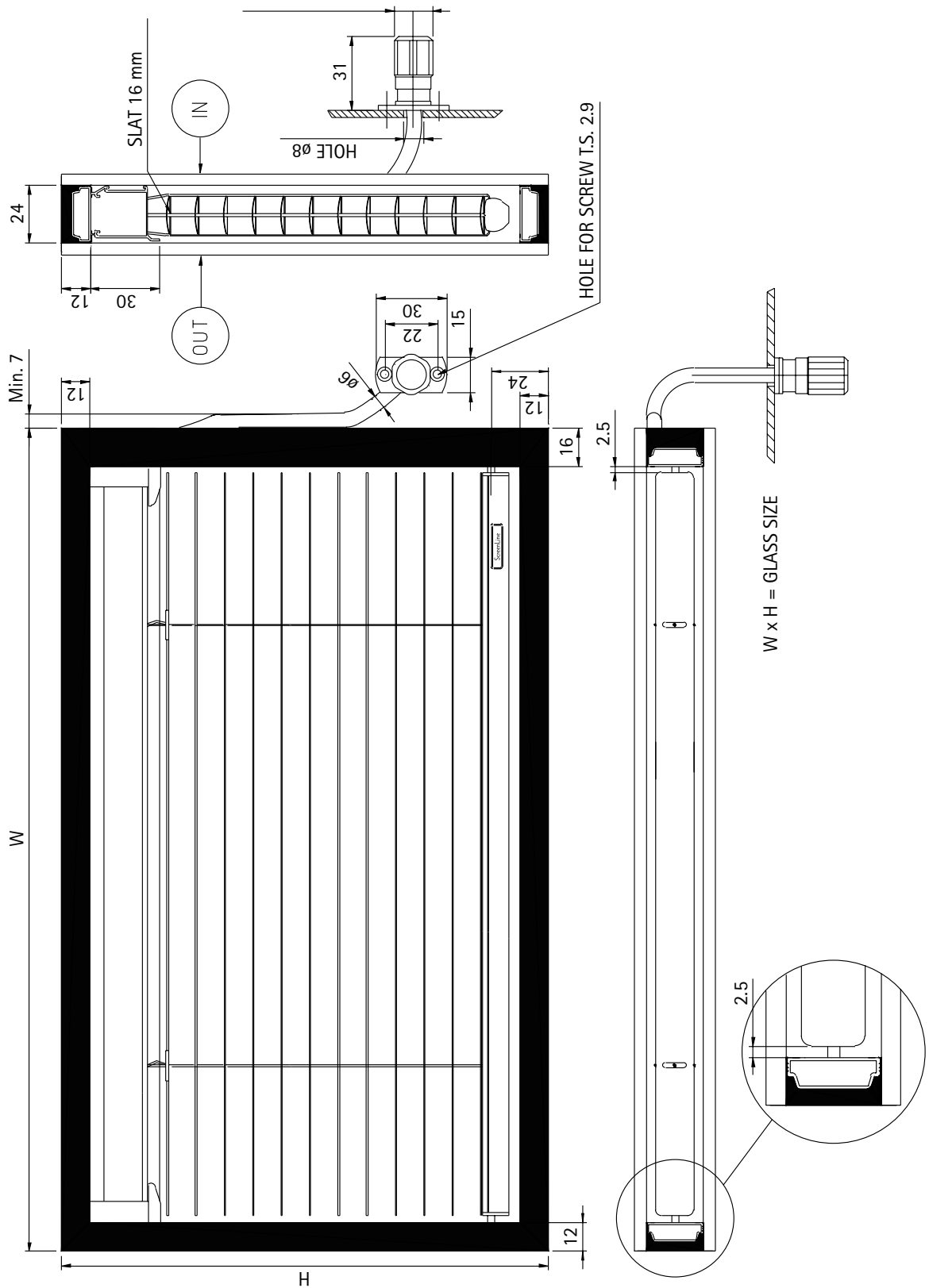

Double-glazed unit with round knob

SL24P

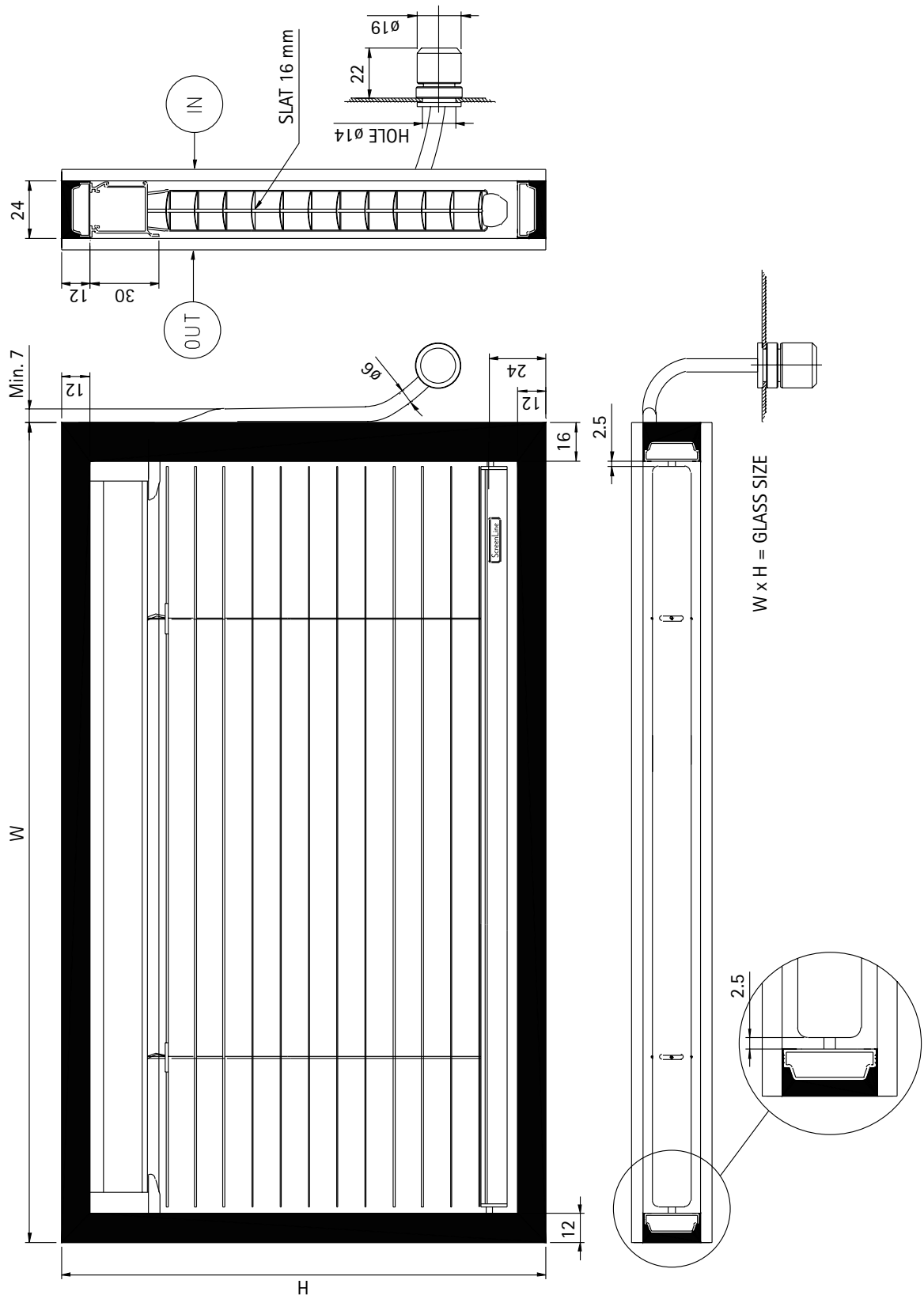

SL24P Double-glazed unit with hidden knob

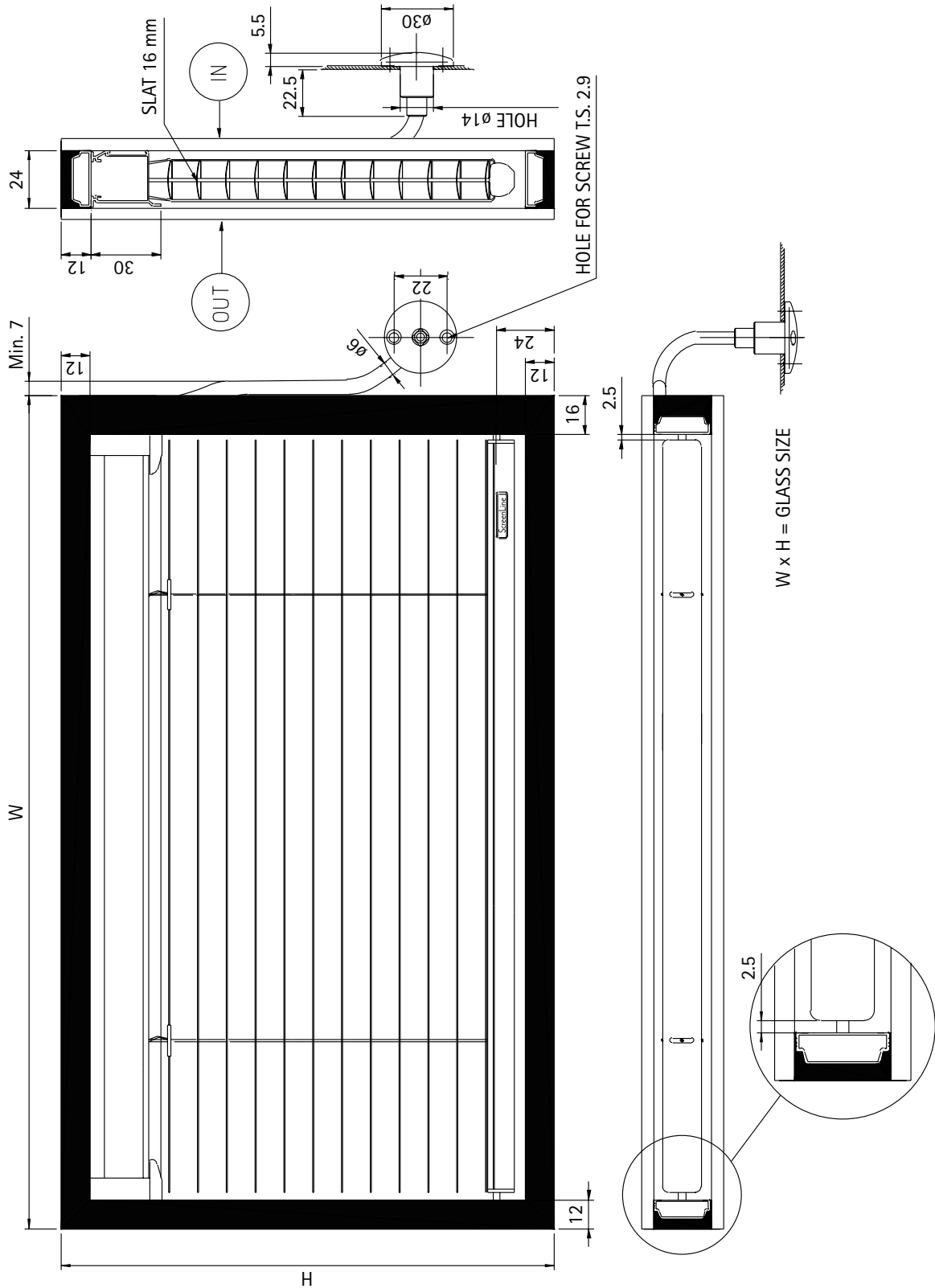

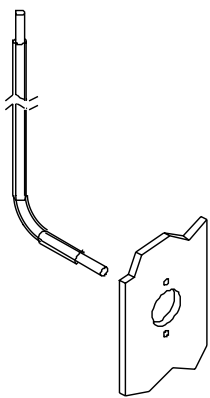

1

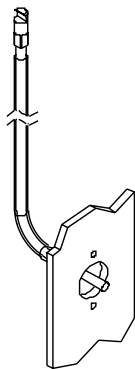

2

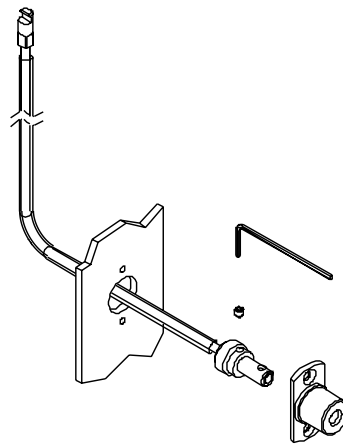

3

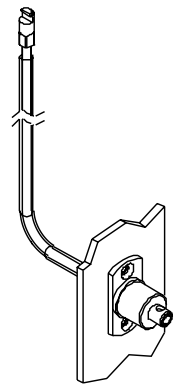

4

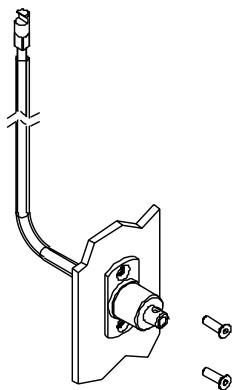

5

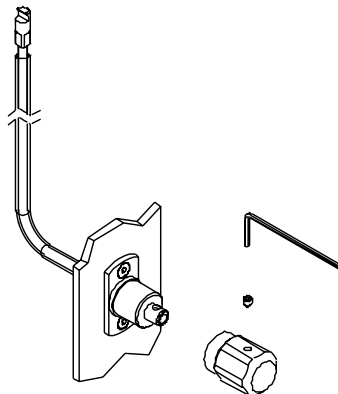

6

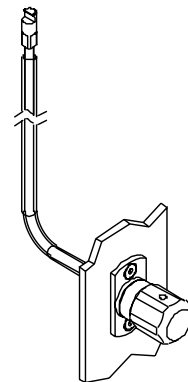

7

SL24P Round knob assembly

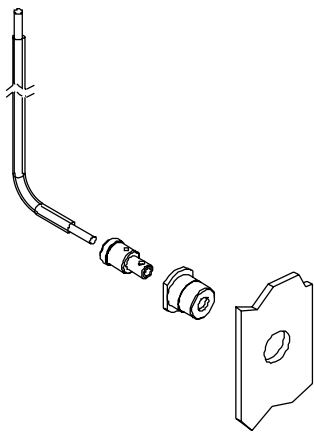

1

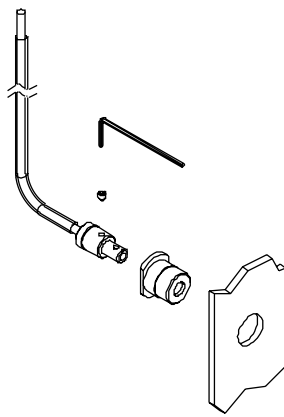

2

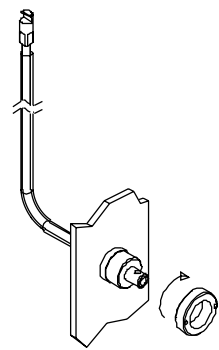

3

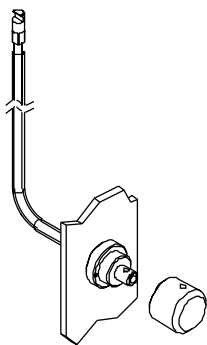

4

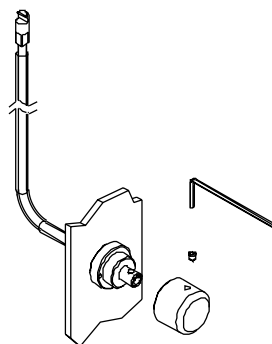

5

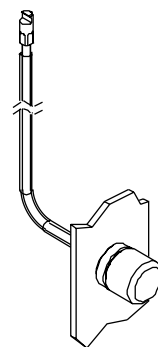

6

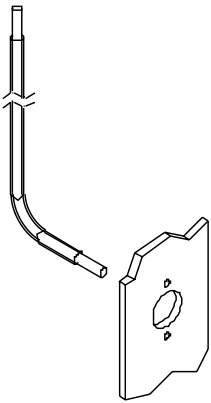

1

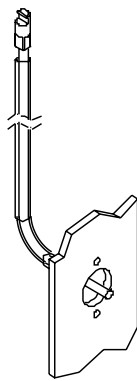

2

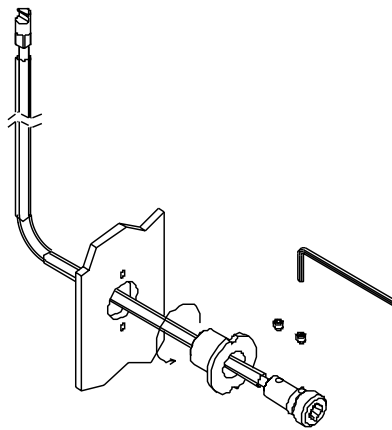

3

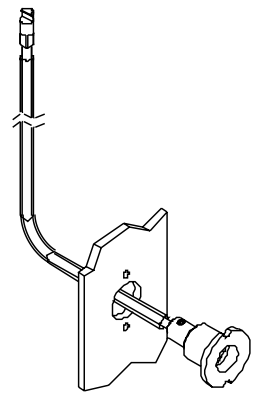

4

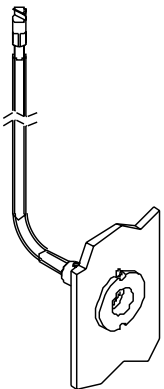

5

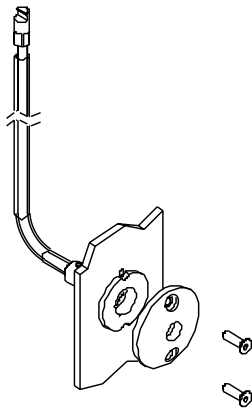

6

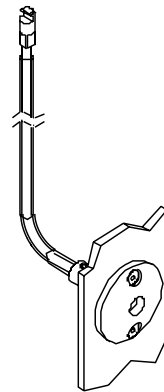

7

Height	Width																													
	40	50	60	70	80	90	100	110	120	130	140	150	160	170	180	190	200	210	220	230	240	250	260	270	280	290	300			
L	S	S	S	S	S	S	S	S	S	S	S	S	S	S	S	S	S	S	S	S	S	S	S	S	S	S	S	S		
30	S	S	S	S	S	S	S	S	S	S	S	S	S	S	S	S	S	S	S	S	S	S	S	S	S	S	S	S		
40	S	S	S	S	S	S	S	S	S	S	S	S	S	S	S	S	S	S	S	S	S	S	S	S	S	S	S	S		
50	S	S	S	S	S	S	S	S	S	S	S	S	S	S	S	S	S	S	S	S	S	S	S	S	S	S	S	S		
60	S	S	S	S	S	S	S	S	S	S	S	S	S	S	S	S	S	S	S	S	S	S	S	S	S	S	S	S		
70	S	S	S	S	S	S	S	S	S	S	S	S	S	S	S	S	S	S	S	S	S	S	S	S	S	S	S	S		
80	S	S	S	S	S	S	S	S	S	S	S	S	S	S	S	S	S	S	S	S	S	S	S	S	S	S	S	S		
90	S	S	S	S	S	S	S	S	S	S	S	S	S	S	S	S	S	S	S	S	S	S	S	S	S	S	S	S		
100	S	S	S	S	S	S	S	S	S	S	S	S	S	S	S	S	S	S	S	S	S	S	S	S	S	S	S	S		
110	S	S	S	S	S	S	S	S	S	S	S	S	S	S	S	S	S	S	S	S	S	S	S	S	S	S	S	S		
120	S	S	S	S	S	S	S	S	S	S	S	S	S	S	S	S	S	S	S	S	S	S	S	S	S	S	S	S		
130	S	S	S	S	S	S	S	S	S	S	S	S	S	S	S	S	S	S	S	S	S	S	S	S	S	S	S	S		
140	S	S	S	S	S	S	S	S	S	S	S	S	S	S	S	S	S	S	S	S	S	S	S	S	S	S	S	S		
150	S	S	S	S	S	S	S	S	S	S	S	S	S	S	S	S	S	S	S	S	S	S	S	S	S	S	S	S		
160	S	S	S	S	S	S	S	S	S	S	S	S	S	S	S	S	S	S	S	S	S	S	S	S	S	S	S	S		
170	S	S	S	S	S	S	S	S	S	S	S	S	S	S	S	S	S	S	S	S	S	S	S	S	S	S	S	S		
180	S	S	S	S	S	S	S	S	S	S	S	S	S	S	S	S	S	S	S	S	S	S	S	S	S	S	S	S		
190	S	S	S	S	S	S	S	S	S	S	S	S	S	S	S	S	S	S	S	S	S	S	S	S	S	S	S	S		
200	S	S	S	S	S	S	S	S	S	S	S	S	S	S	S	S	S	S	S	S	S	S	S	S	S	S	S	S		
210	S	S	S	S	S	S	S	S	S	S	S	S	S	S	S	S	S	S	S	S	S	S	S	S	S	S	S	S		
220	S	S	S	S	S	S	S	S	S	S	S	S	S	S	S	S	S	S	S	S	S	S	S	S	S	S	S	S		
230	S	S	S	S	S	S	S	S	S	S	S	S	S	S	S	S	S	S	S	S	S	S	S	S	S	S	S	S		
240	S	S	S	S	S	S	S	S	S	S	S	S	S	S	S	S	S	S	S	S	S	S	S	S	S	S	S	S		
250	S	S	S	S	S	S	S	S	S	S	S	S	S	S	S	S	S	S	S	S	S	S	S	S	S	S	S	S		
260	S	S	S	S	S	S	S	S	S	S	S	S	S	S	S	S	S	S	S	S	S	S	S	S	S	S	S	S		
270	S	S	S	S	S	S	S	S	S	S	S	S	S	S	S	S	S	S	S	S	S	S	S	S	S	S	S	S		
280	S	S	S	S	S	S	S	S	S	S	S	S	S	S	S	S	S	S	S	S	S	S	S	S	S	S	S	S		
290	S	S	S	S	S	S	S	S	S	S	S	S	S	S	S	S	S	S	S	S	S	S	S	S	S	S	S	S		
300	S	S	S	S	S	S	S	S	S	S	S	S	S	S	S	S	S	S	S	S	S	S	S	S	S	S	S	S		

Out of warranty



Not-feasible



Standard System



ScreenLine® kit components

On receipt of goods, check integrity of package and confirm components as detailed on Purchase Order.

The elements of the kit comprise: **A**

- venetian blind with head-rail / top spacer bar (attached) / special corner keys (one with flexible coupling) altogether with factory applied double sided adhesive tape
- 1 No. bottom spacer bar
- 2 No. Standard profile spacer bar with 'pins' factory fixed (height)
- 2 No. Standard corner keys
- standard Knob control complete with flexible cable, flexible cable cover and connection.

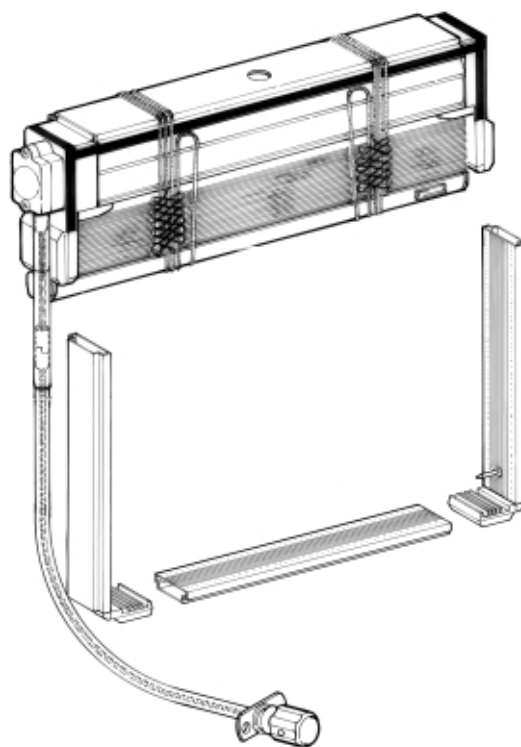

A Kit

Assembly of the integral blind unit

Spacer bar preparation

Assemble the sides and bottom 24 mm spacer bar, fill with the required amount of molecular sieve **B**, and butyl **C** using temporary standard corner keys. (See Manufacturer's quality scheme, page 38).

Line assembly

Pass the first glass through the washer on its base. Remove the plastic wrap from the head-rail / blind, unwind the cords from the head-rail but keep the slats stacked. Holding the spacer frame vertically, remove the temporary corner keys, position the head-rail / integral corner keys over their respective spacer and assemble. **D** Lower the blind taking care not to damage or contaminate the slats with butyl. **E** Insert the bottom rail onto the retaining 'pin' one side of the unit. **F** Open the corner key in the opposite corner, locate the bottom rail on the second restraining 'pin' and then close the corner key taking care to complete the butyl seal. The protective film can then be removed from the double-sided head-rail tape. Position the assembled blind and spacer frame on the first clean glass **G1** ensure that it is parallel and

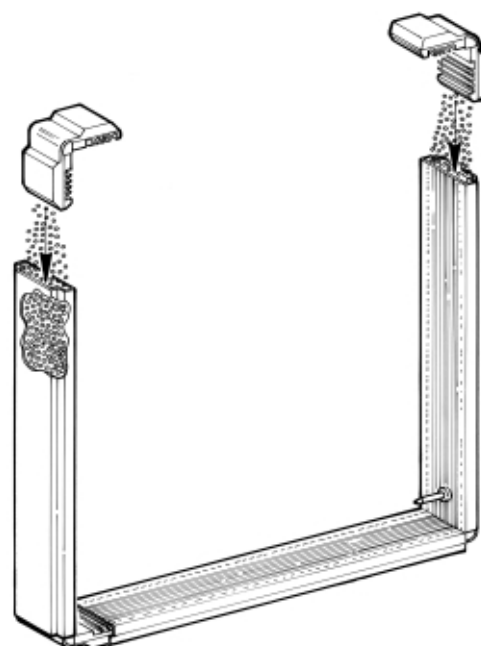

B Desiccant filling

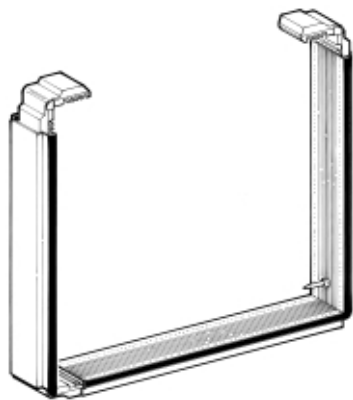

C Spacer assembly

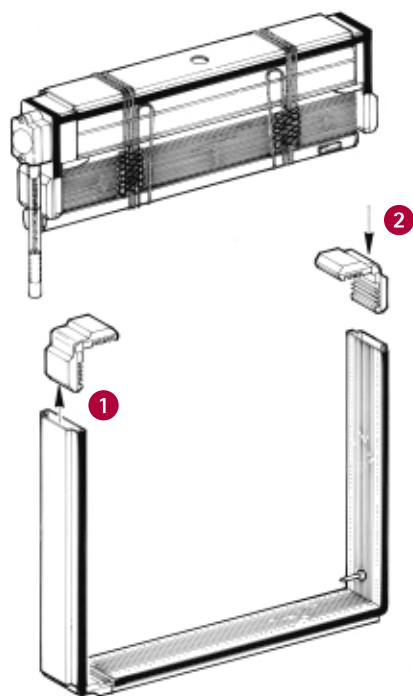

D Kit assembly

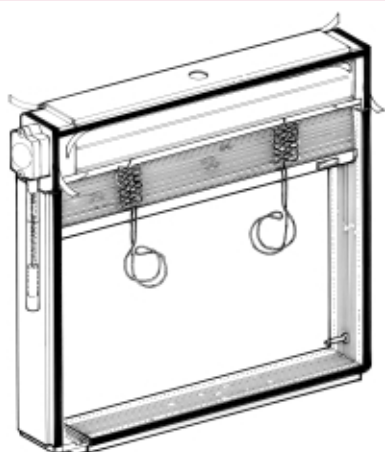

E Blind lowering

square, and there is an 8 mm clearance between the vertical spacer and the edge of the glass on the 'wire' drive side. Check that the slats rotate and position them with the slat face convex to the external glass. Press firmly to achieve good adhesion.

Now assemble the clean second glass. **G2**

Gas filling

Using the appropriate equipment and following the requisite procedures replace the internal air with Argon.

Test

Prior to the final seal it is recommended that the blind operation is checked. The unit must be vertical with the head-rail horizontal at the top of the unit. Check that the slat clearance with the spacer bar is uniform and then rotate the slats by means of the short flexible drive.

Final seal

Rotate the slats to their mid-position i.e. open, and apply the final seal. It is essential that the area around the wire drive is fully enclosed with sealant. **H**

During this operation it is important that the plastic protective sleeve covers the wire drive in order to prevent sealant contamination. **I** It is recommended that a small wedge is used to keep the wire drive free of the sealant until it is cured when the protective PVC sleeve may be removed.

Note

1. SL24P systems must not be inverted (vertically or horizontally) and should only be stored or moved in the vertical plane.
2. The knob control system should be in place on the window frame prior to or during glazing.

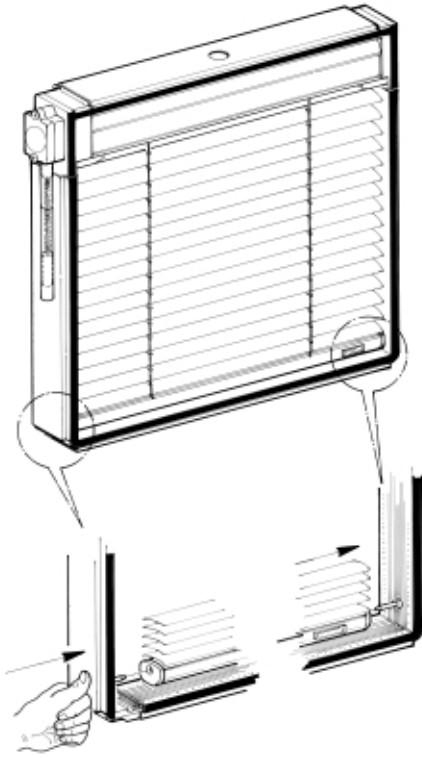

F Bottom rail location

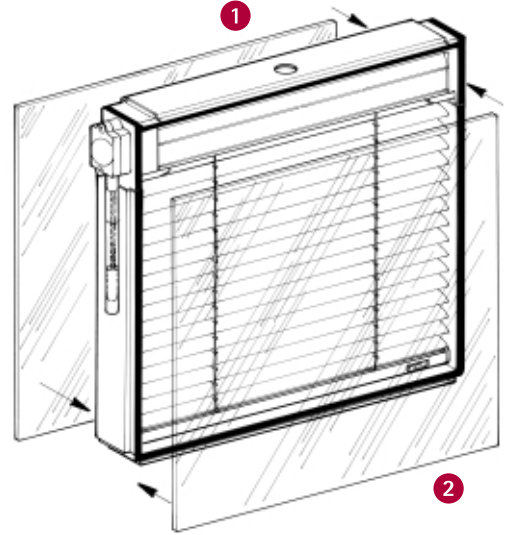

G D.G. assembly

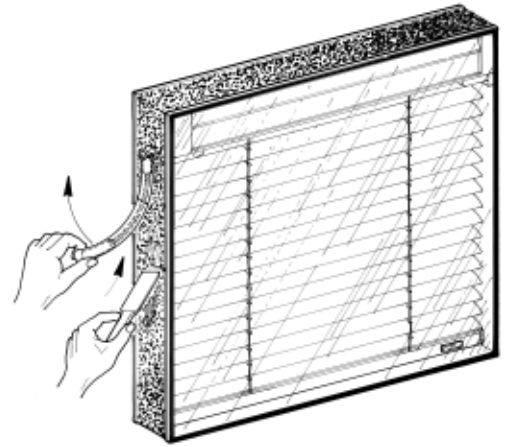

H Unit sealing

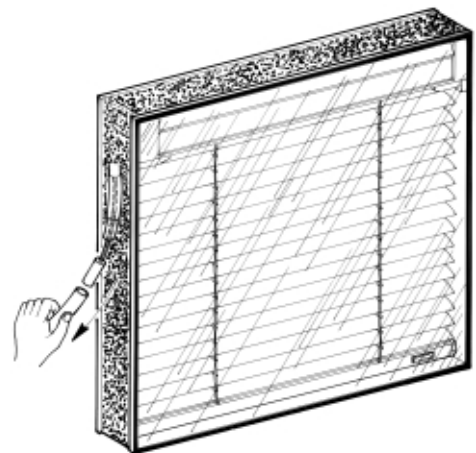

I External wire drive