

SL18C plissé

Technical specification

The ScreenLine® pleated blind SL18C for use in double-glazed units, is manufactured in accordance with high technical specifications and production standards. The pleated blind operation is achieved using a rotational magnetic transmission through the glass thereby guaranteeing the unit's hermetic seal. The external magnet, fixed to the internal glass by double-sided high performance adhesive allows perfect alignment with the internal magnet. The raising and lowering operation is achieved using a continuous cord loop that drives the external magnet. The cord is held lightly under tension by a cord tensioner on the glass directly below the external magnet.

Technical features

Magnetic drive components

Fibreglass re-inforced nylon 66 casings. Transmission gears and parts manufactured from carbon-nitride steel. Ball bearing support for both magnets and gears.

Neodymium-Iron-Boron magnets with the following technical features:

Energy produced	Bh max-Mg.Oe	33-35
Residual induction	Br-Gauss	11.000 / 12.000
Coercive force	Hc-Oestered	10,000
Maximum working temperature	°C	120
Curie temperature	°C	310
Reversible temperature factor	°C	-0.12%

Head rail

Anodised extruded aluminium, A6063S-T5 alloy.

Dimensions: width 18 mm, height 36 mm with pelmet.

Closing profile in anodised aluminium, with acrylic high performance double-adhesive tape.

Verosol fabric

Woven polyester fabric with an aluminium microfilm applied through an exclusive vacuum technique (three-chamber system). The microfilm adhesion complies with the NEN-ISO 7523 regulations.

Class 1 (one) Flame-Retardant.

Technical Characteristics

	Verosol 316	Verosol 312	Verosol 976
Solar Reflection %	54	63	75
Solar Absorption %	27	31	21
Solar Transmission %	19	7	4
Solar Energy Transmission %	42	35	31
Visible Light Transmission %	18	7	4

Bottom rail

Anodised extruded aluminium A6063S-T5 alloy.

Dimensions: width 14 mm, height 10 mm.

Side guide

Anodised extruded aluminium A6063S-T5 alloy. Dimensions: 18 x 9 mm.

Factory applied acrylic high performance double-adhesive tape.

Cords

Thermo-fixed 100% polyester with internal core. Excellent dimensional stability.

White internal cord, 1.0 mm diameter; light grey external cord, 4 mm diameter.

Spacer bar

Electro-welded aluminium.

Dimensions: 18 x 8 mm.

Double-glazed unit size range

Height	100~2.500 mm
Width	300~1.200 mm
Maximum area	see feasibility tables
Blind pack height	3.0% blind height +45 mm

SL18C plissé Comprehensive drawing with component codes

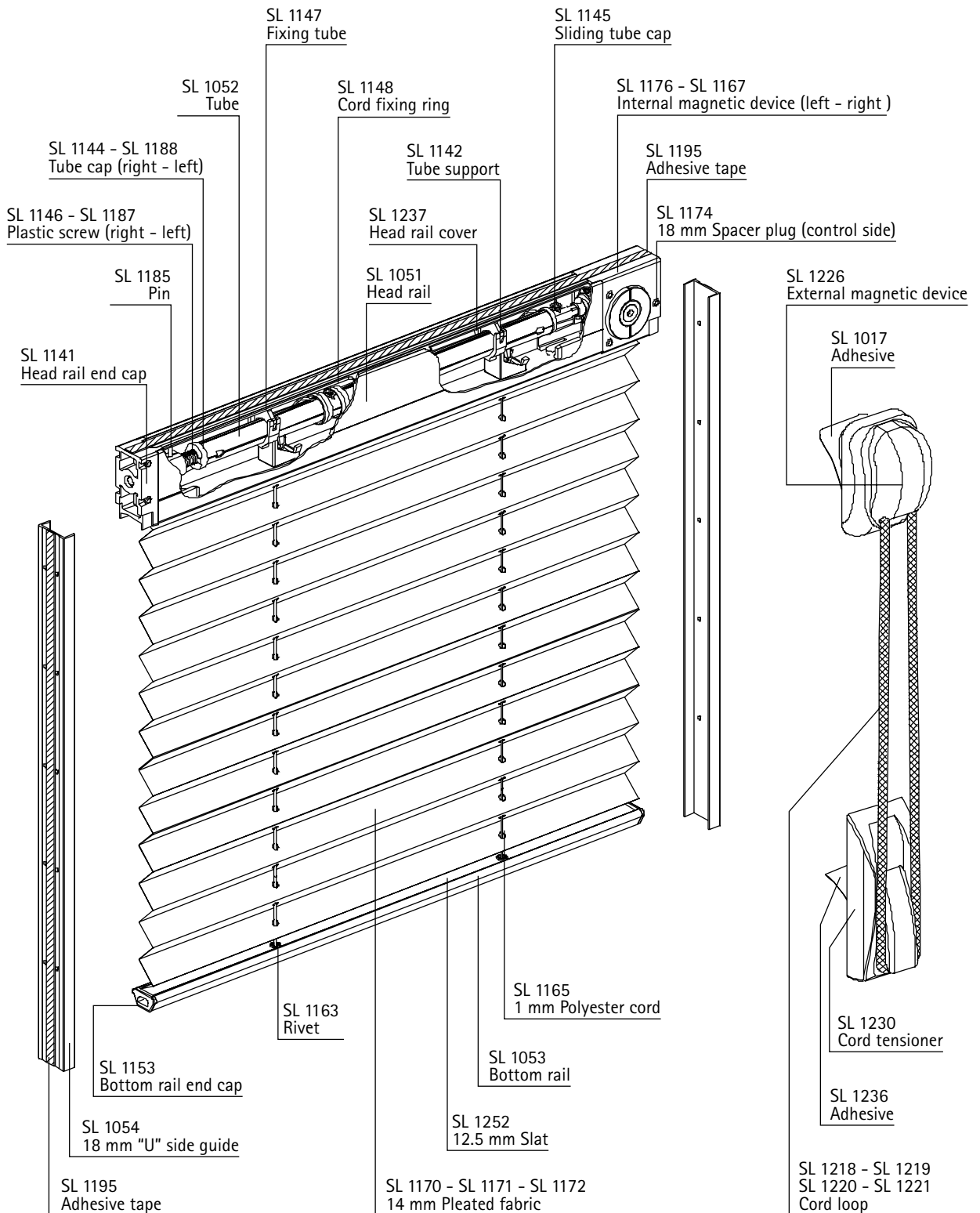

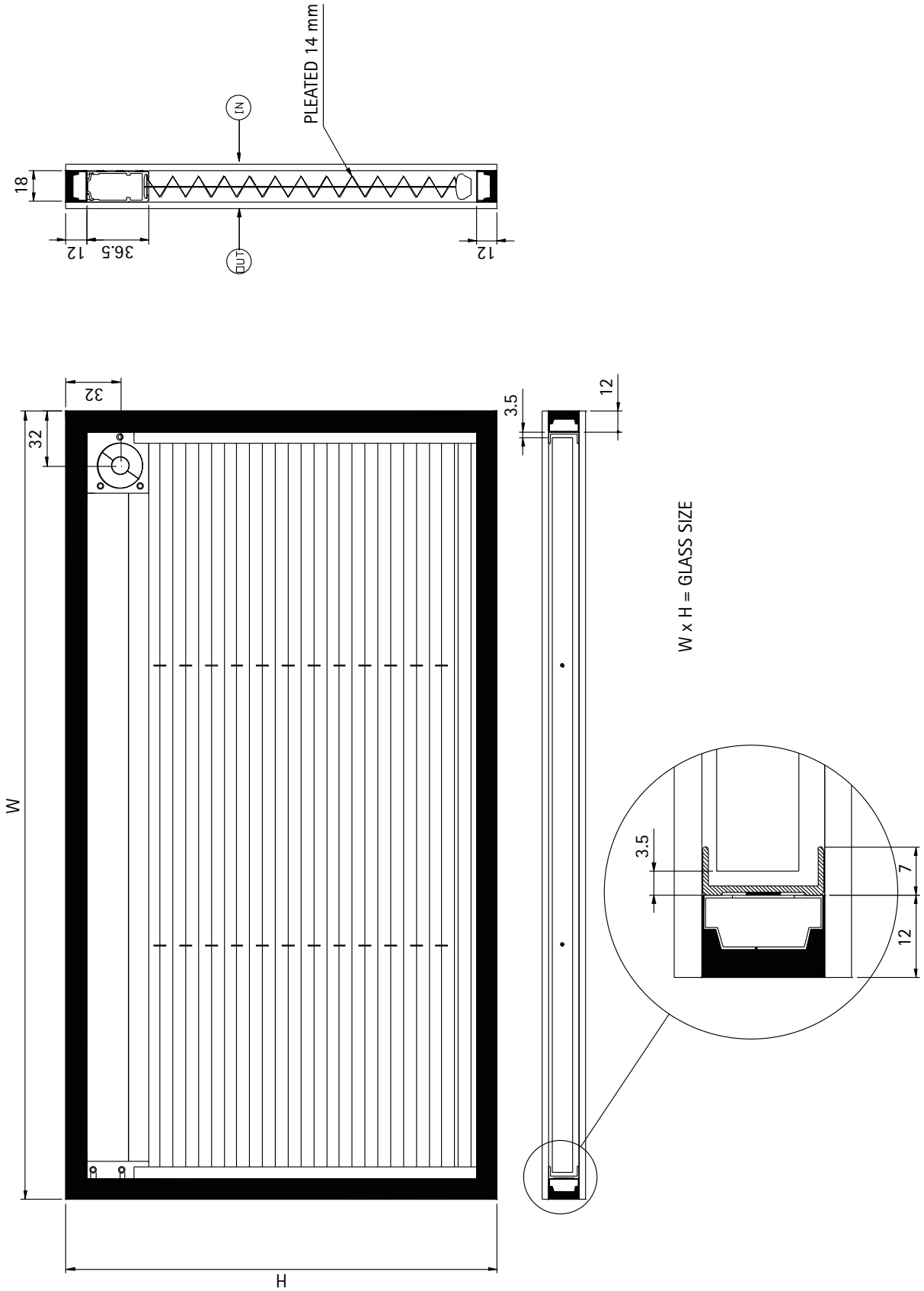

SL18C plissé Double-glazed unit with cord

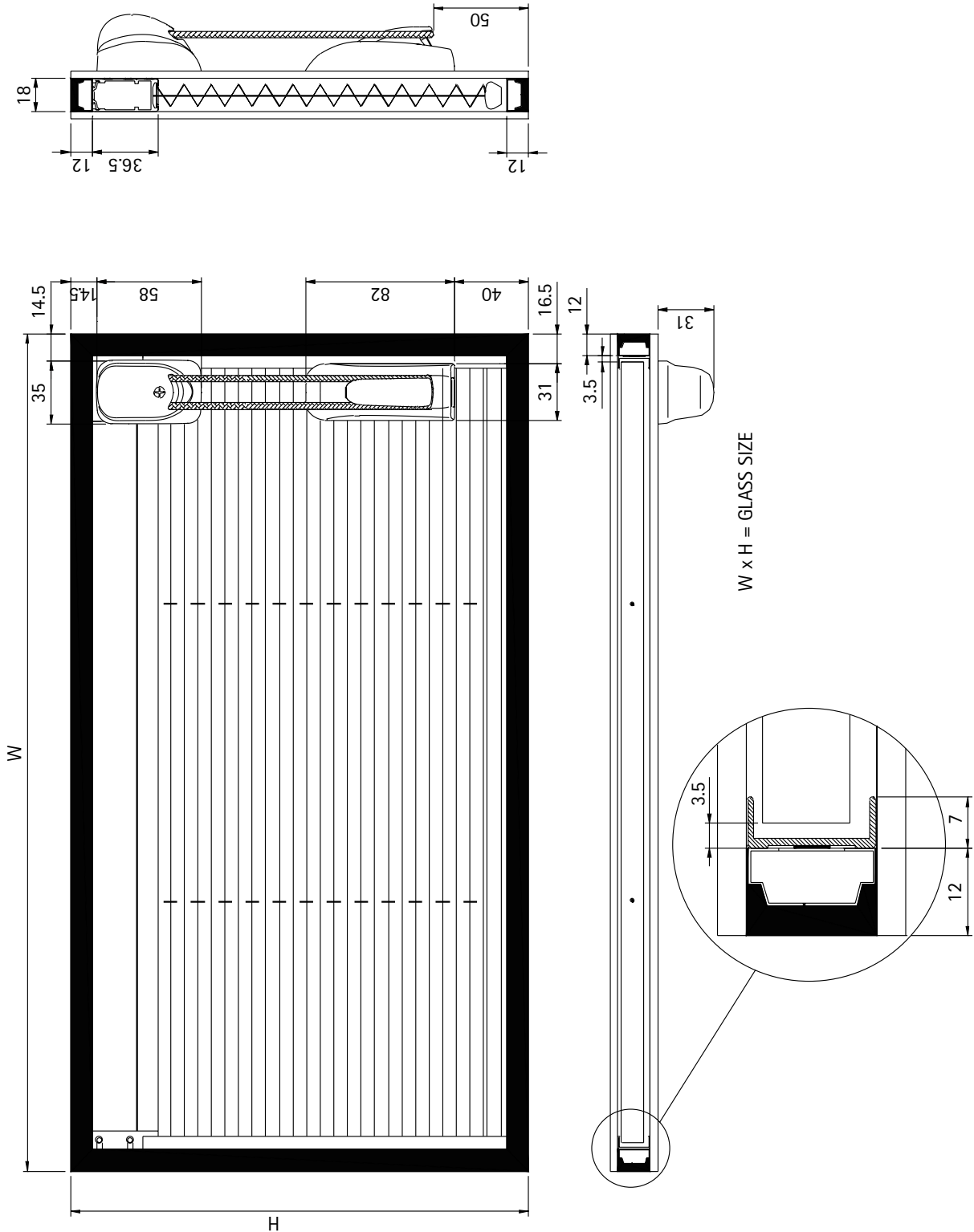

Double-glazed unit with external motor

SL18C plissé

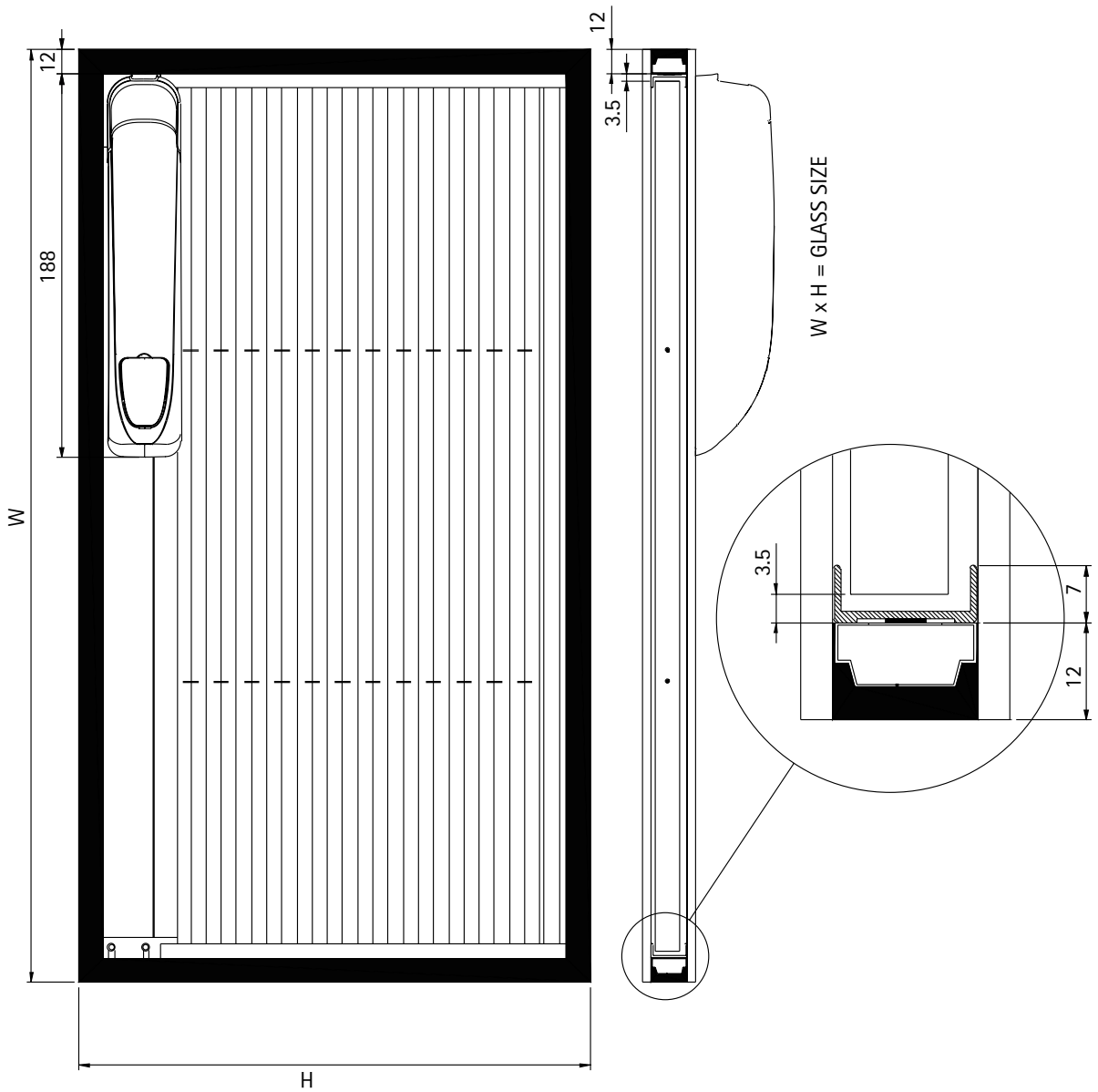
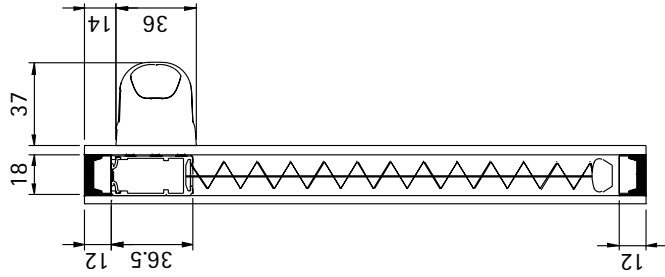

SL18C plissé

Feasibility • 4mm (monolithic) to 7mm (laminated 3+3 mm)

Width		Height																			
		30	35	40	45	50	55	60	65	70	75	80	85	90	95	100	105	110	115	120	
30	S	S	S	S	S	S	S	S	S	S	S	S	S	S	S	S	S	S	S	S	S
40	S	S	S	S	S	S	S	S	S	S	S	S	S	S	S	S	S	S	S	S	S
50	S	S	S	S	S	S	S	S	S	S	S	S	S	S	S	S	S	S	S	S	S
60	S	S	S	S	S	S	S	S	S	S	S	S	S	S	S	S	S	S	S	S	S
70	S	S	S	S	S	S	S	S	S	S	S	S	S	S	S	S	S	S	S	S	S
80	S	S	S	S	S	S	S	S	S	S	S	S	S	S	S	S	S	S	S	S	S
90	S	S	S	S	S	S	S	S	S	S	S	S	S	S	S	S	S	S	S	S	S
100	S	S	S	S	S	S	S	S	S	S	S	S	S	S	S	S	S	S	S	S	S
110	S	S	S	S	S	S	S	S	S	S	S	S	S	S	S	S	S	S	S	S	S
120	S	S	S	S	S	S	S	S	S	S	S	S	S	S	S	S	S	S	S	S	S
130	S	S	S	S	S	S	S	S	S	S	S	S	S	S	S	S	S	S	S	S	S
140	S	S	S	S	S	S	S	S	S	S	S	S	S	S	S	S	S	S	S	S	S
150	S	S	S	S	S	S	S	S	S	S	S	S	S	S	S	S	S	S	S	S	S
160	S	S	S	S	S	S	S	S	S	S	S	S	S	S	S	S	S	S	S	S	S
170	S	S	S	S	S	S	S	S	S	S	S	S	S	S	S	S	S	S	S	S	S
180	S	S	S	S	S	S	S	S	S	S	S	S	S	S	S	S	S	S	S	S	S
190	S	S	S	S	S	S	S	S	S	S	S	S	S	S	S	S	S	S	S	S	S
200	S	S	S	S	S	S	S	S	S	S	S	S	S	S	S	S	S	S	S	S	S
210	S	S	S	S	S	S	S	S	S	S	S	S	S	S	S	S	S	S	S	S	S
220	S	S	S	S	S	S	S	S	S	S	S	S	S	S	S	S	S	S	S	S	S
230	S	S	S	S	S	S	S	S	S	S	S	S	S	S	S	S	S	S	S	S	S
240	S	S	S	S	S	S	S	S	S	S	S	S	S	S	S	S	S	S	S	S	S
250	S	S	S	S	S	S	S	S	S	S	S	S	S	S	S	S	S	S	S	S	S

Out of warranty



Not-feasible



Standard System



SL18C plissé

Feasibility • glass thickness 9mm (laminated 4+4 mm)

Height	Width																									
	30	35	40	45	50	55	60	65	70	75	80	85	90	95	100	105	110	115	120	125	130	135	140	145	150	
30	S	S	S	S	S	S	S	S	S	S	S	S	S	S	S	S	S	S	S	S	S	S	S	S	S	S
40	S	S	S	S	S	S	S	S	S	S	S	S	S	S	S	S	S	S	S	S	S	S	S	S	S	S
50	S	S	S	S	S	S	S	S	S	S	S	S	S	S	S	S	S	S	S	S	S	S	S	S	S	S
60	S	S	S	S	S	S	S	S	S	S	S	S	S	S	S	S	S	S	S	S	S	S	S	S	S	S
70	S	S	S	S	S	S	S	S	S	S	S	S	S	S	S	S	S	S	S	S	S	S	S	S	S	S
80	S	S	S	S	S	S	S	S	S	S	S	S	S	S	S	S	S	S	S	S	S	S	S	S	S	S
90	S	S	S	S	S	S	S	S	S	S	S	S	S	S	S	S	S	S	S	S	S	S	S	S	S	S
100	S	S	S	S	S	S	S	S	S	S	S	S	S	S	S	S	S	S	S	S	S	S	S	S	S	S
110	S	S	S	S	S	S	S	S	S	S	S	S	S	S	S	S	S	S	S	S	S	S	S	S	S	S
120	S	S	S	S	S	S	S	S	S	S	S	S	S	S	S	S	S	S	S	S	S	S	S	S	S	S
130	S	S	S	S	S	S	S	S	S	S	S	S	S	S	S	S	S	S	S	S	S	S	S	S	S	S
140	S	S	S	S	S	S	S	S	S	S	S	S	S	S	S	S	S	S	S	S	S	S	S	S	S	S
150	S	S	S	S	S	S	S	S	S	S	S	S	S	S	S	S	S	S	S	S	S	S	S	S	S	S
160	S	S	S	S	S	S	S	S	S	S	S	S	S	S	S	S	S	S	S	S	S	S	S	S	S	S
170	S	S	S	S	S	S	S	S	S	S	S	S	S	S	S	S	S	S	S	S	S	S	S	S	S	S
180	S	S	S	S	S	S	S	S	S	S	S	S	S	S	S	S	S	S	S	S	S	S	S	S	S	S
190	S	S	S	S	S	S	S	S	S	S	S	S	S	S	S	S	S	S	S	S	S	S	S	S	S	S
200	S	S	S	S	S	S	S	S	S	S	S	S	S	S	S	S	S	S	S	S	S	S	S	S	S	S
210	S	S	S	S	S	S	S	S	S	S	S	S	S	S	S	S	S	S	S	S	S	S	S	S	S	S
220	S	S	S	S	S	S	S	S	S	S	S	S	S	S	S	S	S	S	S	S	S	S	S	S	S	S
230	S	S	S	S	S	S	S	S	S	S	S	S	S	S	S	S	S	S	S	S	S	S	S	S	S	S
240	S	S	S	S	S	S	S	S	S	S	S	S	S	S	S	S	S	S	S	S	S	S	S	S	S	S
250	S	S	S	S	S	S	S	S	S	S	S	S	S	S	S	S	S	S	S	S	S	S	S	S	S	S

Out of warranty



Not-feasible



Standard System



Feasibility • glass thickness 10mm (monolithic)

SL18C plissé

Height	Width																									
	30	35	40	45	50	55	60	65	70	75	80	85	90	95	100	105	110	115	120	125	130	135	140	145	150	
30	S	S	S	S	S	S	S	S	S	S	S	S	S	S	S	S	S	S	S	S	S	S	S	S	S	S
40	S	S	S	S	S	S	S	S	S	S	S	S	S	S	S	S	S	S	S	S	S	S	S	S	S	S
50	S	S	S	S	S	S	S	S	S	S	S	S	S	S	S	S	S	S	S	S	S	S	S	S	S	S
60	S	S	S	S	S	S	S	S	S	S	S	S	S	S	S	S	S	S	S	S	S	S	S	S	S	S
70	S	S	S	S	S	S	S	S	S	S	S	S	S	S	S	S	S	S	S	S	S	S	S	S	S	S
80	S	S	S	S	S	S	S	S	S	S	S	S	S	S	S	S	S	S	S	S	S	S	S	S	S	S
90	S	S	S	S	S	S	S	S	S	S	S	S	S	S	S	S	S	S	S	S	S	S	S	S	S	S
100	S	S	S	S	S	S	S	S	S	S	S	S	S	S	S	S	S	S	S	S	S	S	S	S	S	S
110	S	S	S	S	S	S	S	S	S	S	S	S	S	S	S	S	S	S	S	S	S	S	S	S	S	S
120	S	S	S	S	S	S	S	S	S	S	S	S	S	S	S	S	S	S	S	S	S	S	S	S	S	S
130	S	S	S	S	S	S	S	S	S	S	S	S	S	S	S	S	S	S	S	S	S	S	S	S	S	S
140	S	S	S	S	S	S	S	S	S	S	S	S	S	S	S	S	S	S	S	S	S	S	S	S	S	S
150	S	S	S	S	S	S	S	S	S	S	S	S	S	S	S	S	S	S	S	S	S	S	S	S	S	S
160	S	S	S	S	S	S	S	S	S	S	S	S	S	S	S	S	S	S	S	S	S	S	S	S	S	S
170	S	S	S	S	S	S	S	S	S	S	S	S	S	S	S	S	S	S	S	S	S	S	S	S	S	S
180	S	S	S	S	S	S	S	S	S	S	S	S	S	S	S	S	S	S	S	S	S	S	S	S	S	S
190	S	S	S	S	S	S	S	S	S	S	S	S	S	S	S	S	S	S	S	S	S	S	S	S	S	S
200	S	S	S	S	S	S	S	S	S	S	S	S	S	S	S	S	S	S	S	S	S	S	S	S	S	S
210	S	S	S	S	S	S	S	S	S	S	S	S	S	S	S	S	S	S	S	S	S	S	S	S	S	S
220	S	S	S	S	S	S	S	S	S	S	S	S	S	S	S	S	S	S	S	S	S	S	S	S	S	S
230	S	S	S	S	S	S	S	S	S	S	S	S	S	S	S	S	S	S	S	S	S	S	S	S	S	S
240	S	S	S	S	S	S	S	S	S	S	S	S	S	S	S	S	S	S	S	S	S	S	S	S	S	S
250	S	S	S	S	S	S	S	S	S	S	S	S	S	S	S	S	S	S	S	S	S	S	S	S	S	S

Standard System
 Not-feasible
 Out of warranty

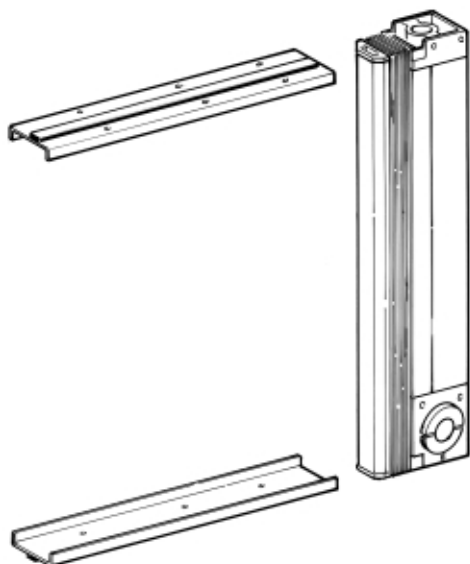

A Kit

ScreenLine® kit components

When the goods are delivered, please check the integrity of the package and confirm that the components are as the Purchase Order. The elements of the kit should comprise: **A**

- pleated blind with adhesive tape on the head rail
- U-channel side guides with adhesive tape
- external magnetic control plus cord with cord tensioner, both with adhesive tape
- spacer bars and corner keys – on request.

Assembly of the integral blind unit

Spacer bar preparation

Fill the spacer bars with required amount of molecular sieve and hot extrude the butyl on them in a continuous line. (See Manufacturer's quality scheme, page 38). If you use your own spacer bar, check their size. The blind head rail, as well as the side guides must be inserted inside them with a maximum 1 mm variation.

Line assembly

Pass the first glass through the glass either on its base or height.

Position the spacer frame uniformly on the glass ensuring it is perfectly parallel and square (avoid inwards deflection of the spacer bar) and press to obtain a high degree of adhesion. **B**

Remove the pleated blind from its plastic package. Pay attention not to lose the pins around the internal mag-

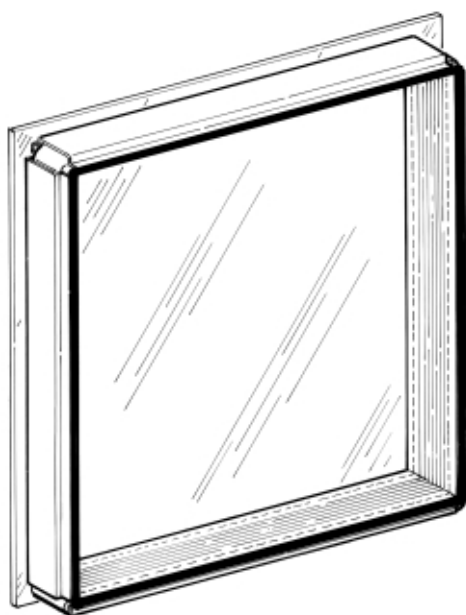

B Spacer bars – glass assembly

net. Remove the protective film from the double-sided adhesive tape on the head rail. **C1**

Stick the head rail onto the respective spacer bar and press together. Use the glass as a guide / support. **C**

During this operation ensure that the internal magnet faces the internal surface of the inner glass. **D**

Position the U shaped side guides into the appropriate location at the each end of the head rail. After inserting the guides, remove the double-adhesive protective film and stick them onto the respective spacer bars using the glass surface as a guide / support. **D4 D5**

During this operation, avoid bending the side guides towards the internal side of the glass.

Finally assemble the second glass. **E**

Gas filling

Using the appropriate equipment and following the requisite procedure replace the internal air with argon.

Testing

Prior to sealing the perimeter position the unit vertically with the blind at the top and test the blind using the cord operated external magnetic device. During this operation check that the fabric and the bottom rail function inside the side guides and that the guide distance from the bottom is even.

Second sealing

Raise the blind and apply the final seal following the Manufacturer's quality scheme (page 38). **F**

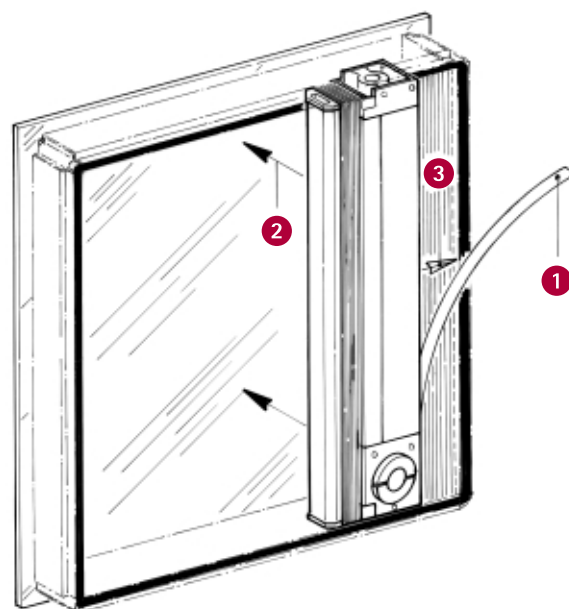

C Blind insertion

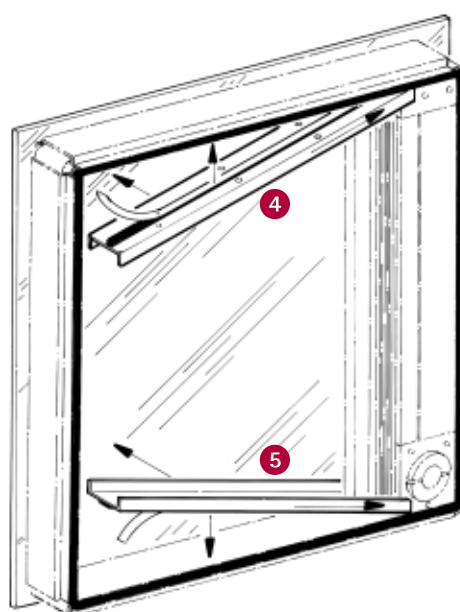

D Side guides insertion

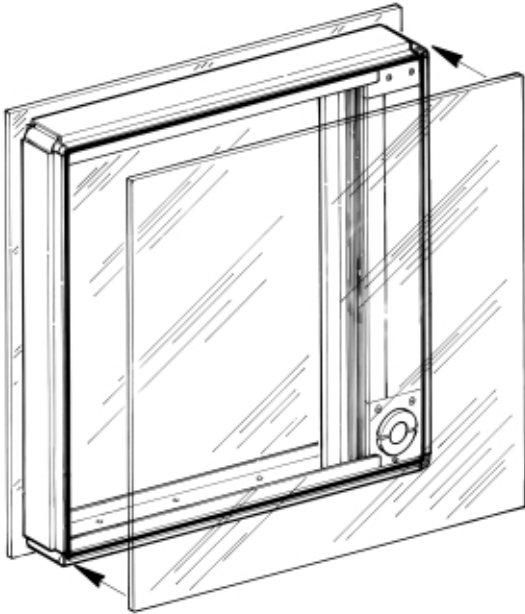

E Second glass assembly

Note

1. Always ensure that the blind is completely raised when turning the unit.
2. The external magnet and cord tensioner should only be applied to the glass surface after glazing. Please ensure the glass surface is cleaned correctly to obtain good adhesion.
3. The use of the stainless steel base plate allows greater accuracy when locating the external magnet over the internal magnet in order to achieve perfect alignment. During this operation ensure the glass is clean.

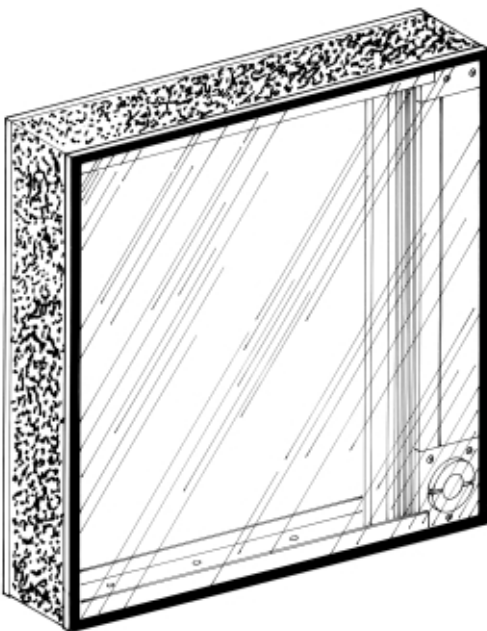

F Final seal